



# MMBT4403

## PNP SILICON TRANSISTOR

### PNP GENERAL PURPOSE AMPLIFIER

#### DESCRIPTION

The UTC **MMBT4403** is designed for use as a general purpose amplifier and switch requiring collector currents up to 500mA.

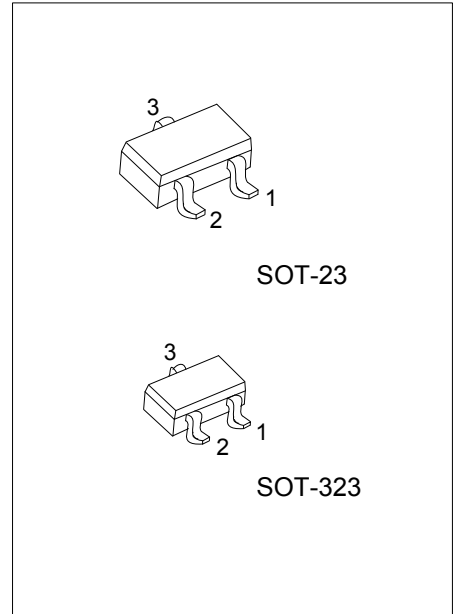

#### ORDERING INFORMATION

Ordering Number	Package	Pin Assignment			Packing
		1	2	3	
MMBT4403G-AE3-R	SOT-23	E	B	C	Tape Reel
MMBT4403G-AL3-R	SOT-323	E	B	C	Tape Reel

Note: Pin Assignment: E: Emitter    B: Base    C: Collector

<p>MMBT4403G-AE3-R</p> <p>(1) Packing Type</p> <p>(2) Package Type</p> <p>(3) Green Package</p>	<p>(1) R: Tape Reel</p> <p>(2) AE3: SOT-23, AL3: SOT-323</p> <p>(3) G: Halogen Free and Lead Free</p>
---	---

#### MARKING

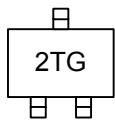

■ ABSOLUTE MAXIMUM RATINGS (T<sub>A</sub>=25°C, unless otherwise specified)

PARAMETER	SYMBOL	RATINGS	UNIT
Collector-Base Voltage	V <sub>CBO</sub>	-40	V
Collector-Emitter Voltage	V <sub>CEO</sub>	-40	V
Emitter-Base Voltage	V <sub>EBO</sub>	-5	V
Collector Current-Continuous	I <sub>C</sub>	-600	mA
Total Device Dissipation	P <sub>C</sub>	350	mW
Derate above 25°C		2.8	mW/°C
Junction Temperature	T <sub>J</sub>	+150	°C
Storage Temperature	T <sub>STG</sub>	-55 ~ +150	°C

- Notes: 1. Absolute maximum ratings are those values beyond which the device could be permanently damaged. Absolute maximum ratings are stress ratings only and functional device operation is not implied.  
 2. These are steady state limits. The factory should be consulted on applications involving pulsed or low duty cycle operations.

■ THERMAL DATA (T<sub>A</sub>=25°C, unless otherwise specified)

CHARACTERISTIC	SYMBOL	RATINGS	UNIT
Junction to Ambient	θ <sub>JA</sub>	357	°C /W

■ ELECTRICAL CHARACTERISTICS (T<sub>A</sub>=25°C, unless otherwise specified)

PARAMETER	SYMBOL	TEST CONDITIONS	MIN	TYP	MAX	UNIT
<b>OFF CHARACTERISTICS</b>						
Collector-Emitter Breakdown Voltage (Note)	BV <sub>CEO</sub>	I <sub>C</sub> =-1mA, I <sub>B</sub> =0	-40			V
Collector-Base Breakdown Voltage	BV <sub>CBO</sub>	I <sub>C</sub> =-0.1mA, I <sub>E</sub> =0	-40			V
Emitter-Base Breakdown Voltage	BV <sub>EBO</sub>	I <sub>E</sub> =-0.1mA, I <sub>C</sub> =0	-5			V
Collector Cut-off Current	I <sub>CEX</sub>	V <sub>CE</sub> =-35V, V <sub>EB</sub> =-0.4V			-0.1	μA
Base Cut-off Current	I <sub>BEX</sub>	V <sub>CE</sub> =-35V, V <sub>BE</sub> =-0.4V			-0.1	μA
<b>ON CHARACTERISTICS*</b>						
DC Current Gain	h <sub>FE1</sub>	V <sub>CE</sub> =-1V, I <sub>C</sub> =-0.1mA	30			
	h <sub>FE2</sub>	V <sub>CE</sub> =-1V, I <sub>C</sub> =-1mA	60			
	h <sub>FE3</sub>	V <sub>CE</sub> =-1V, I <sub>C</sub> =-10mA	100			
	h <sub>FE4</sub>	V <sub>CE</sub> =-2V, I <sub>C</sub> =-150mA (Note)	100		300	
	h <sub>FE5</sub>	V <sub>CE</sub> =-2V, I <sub>C</sub> =-500mA (Note)	20			
Collector-Emitter Saturation Voltage	V <sub>CE(SAT1)</sub>	I <sub>C</sub> =-150mA, I <sub>B</sub> =-15mA			-0.4	V
	V <sub>CE(SAT2)</sub>	I <sub>C</sub> =-500mA, I <sub>B</sub> =-50mA			-0.75	
Base-Emitter Saturation Voltage	V <sub>BE(SAT1)</sub>	I <sub>C</sub> =-150mA, I <sub>B</sub> =-15mA (Note)	-0.75		-0.95	V
	V <sub>BE(SAT2)</sub>	I <sub>C</sub> =-500mA, I <sub>B</sub> =-50mA			-1.3	
<b>SMALL SIGNAL CHARACTERISTICS</b>						
Transition Frequency	f <sub>T</sub>	V <sub>CE</sub> =-10V, I <sub>C</sub> =-20mA, f=100MHz	200			MHz
Collector-Base Capacitance	C <sub>CB</sub>	V <sub>CB</sub> =-10V, I <sub>E</sub> =0, f=140kHz			8.5	pF
Emitter-Base Capacitance	C <sub>EB</sub>	V <sub>BE</sub> =-0.5V, I <sub>C</sub> =0, f=140kHz			30	pF
Input Impedance	h <sub>IE</sub>	V <sub>CE</sub> =-10V, I <sub>C</sub> =-1mA, f=1kHz	1.5		15	kΩ
Voltage Feedback Ratio	h <sub>RE</sub>	V <sub>CE</sub> =-10V, I <sub>C</sub> =-1mA, f=1kHz	0.1		8	×10 <sup>-4</sup>
Small-Signal Current Gain	h <sub>FE</sub>	V <sub>CE</sub> =-10V, I <sub>C</sub> =-1mA, f=1kHz	60		500	
Output Admittance	h <sub>OE</sub>	V <sub>CE</sub> =-10V, I <sub>C</sub> =-1mA, f=1kHz	1.0		100	μmhos
<b>SWITCHING CHARACTERISTICS</b>						
Delay Time	t <sub>D</sub>	V <sub>CC</sub> =-30V, I <sub>C</sub> =-150mA, I <sub>B1</sub> =-15mA			15	ns
Rise Time	t <sub>R</sub>		20			
Storage Time	t <sub>S</sub>	V <sub>CC</sub> =-30V, I <sub>C</sub> =-150mA, I <sub>B1</sub> =I <sub>B2</sub> =-15mA			225	ns
Fall Time	t <sub>F</sub>		30			

Note: Pulse test: Pulse Width≤300μs, Duty Cycles≤2%

■ TEST CIRCUIT

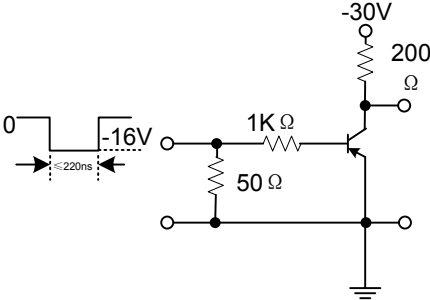

Figure 1. Saturated Turn-On Switching Timer

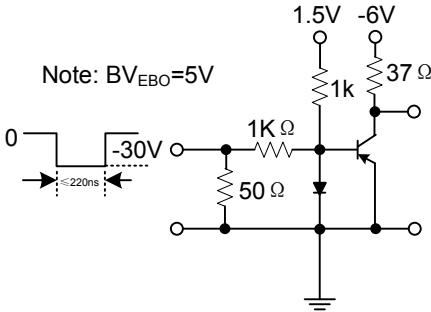
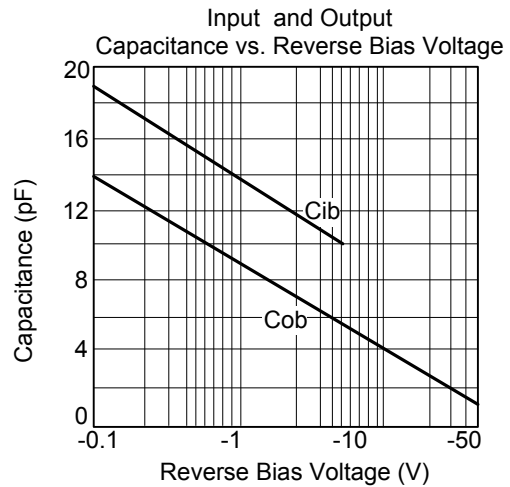
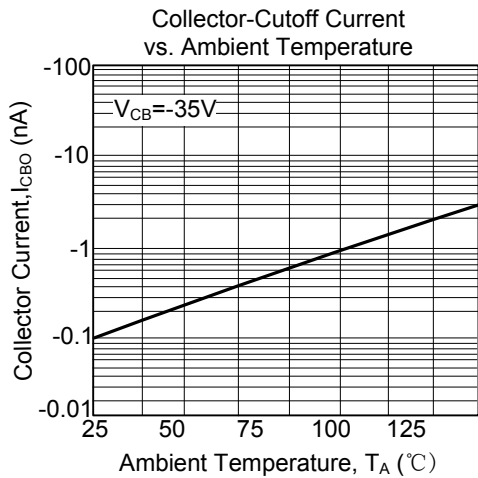
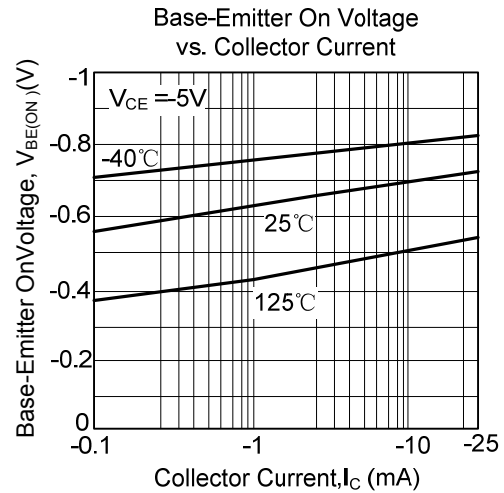
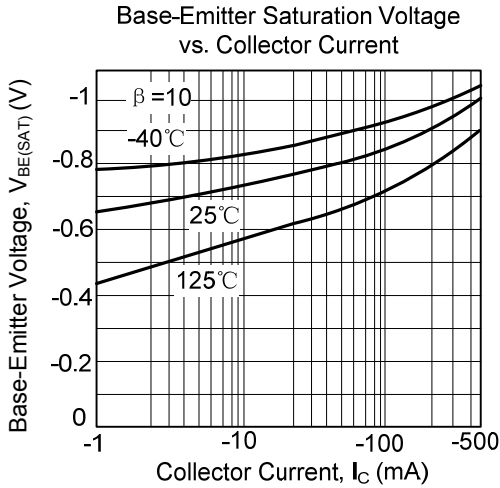
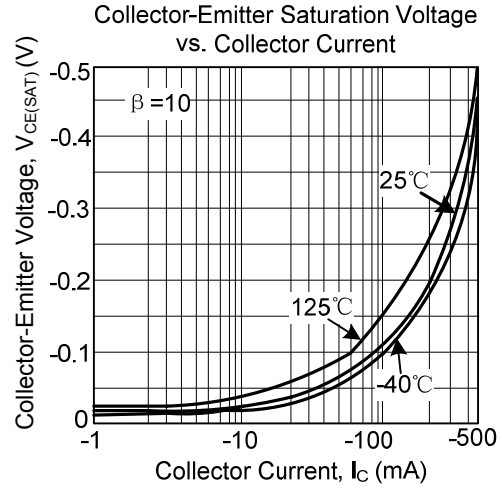
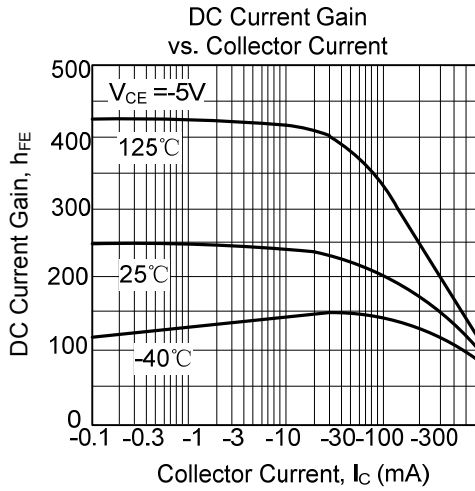

Figure 2. Saturated Turn-Off Switching Timer

### TYPICAL CHARACTERISTICS



UTC assumes no responsibility for equipment failures that result from using products at values that exceed, even momentarily, rated values (such as maximum ratings, operating condition ranges, or other parameters) listed in products specifications of any and all UTC products described or contained herein. UTC products are not designed for use in life support appliances, devices or systems where malfunction of these products can be reasonably expected to result in personal injury. Reproduction in whole or in part is prohibited without the prior written consent of the copyright owner. The information presented in this document does not form part of any quotation or contract, is believed to be accurate and reliable and may be changed without notice.